

Specifications

Authentication authority:	JET	UL	TÜV
Authentication standard:	Electric Appliances and Material Safety Law	UL2251	IEC62196-1
Rated voltage:	100 to 250 V AC	120/240 V AC	100 to 250 V AC
Rated current:	20 A / 30 A	20 A / 30 A	20 A
Number of poles:	POWER 2, GROUND 1, SIGNAL 2		
Cable type:	POWER 2, GROUND 1, SIGNAL 1		
Operation temperature range:	-40 to +60°C		

- 1) Conforming to SAE J1772 specifications
- 2) Conforming to the European ELV and RoHS directives

仕様

認証機関	JET	UL	TÜV
認証規格	電気用品安全法	UL2251	IEC62196-1
定格電圧	AC 100~250 V	AC 120/240 V	AC 100~250 V
定格電流	20 A / 30 A	20 A / 30 A	20 A
極数	POWER 2, GROUND 1, SIGNAL 2		
ケーブル電線	POWER 2, GROUND 1, SIGNAL 1		
動作温度範囲	-40 ~ +60°C		

- 1) SAE J1772 仕様に基づき
- 2) 欧州ELV、RoHS指令に対応

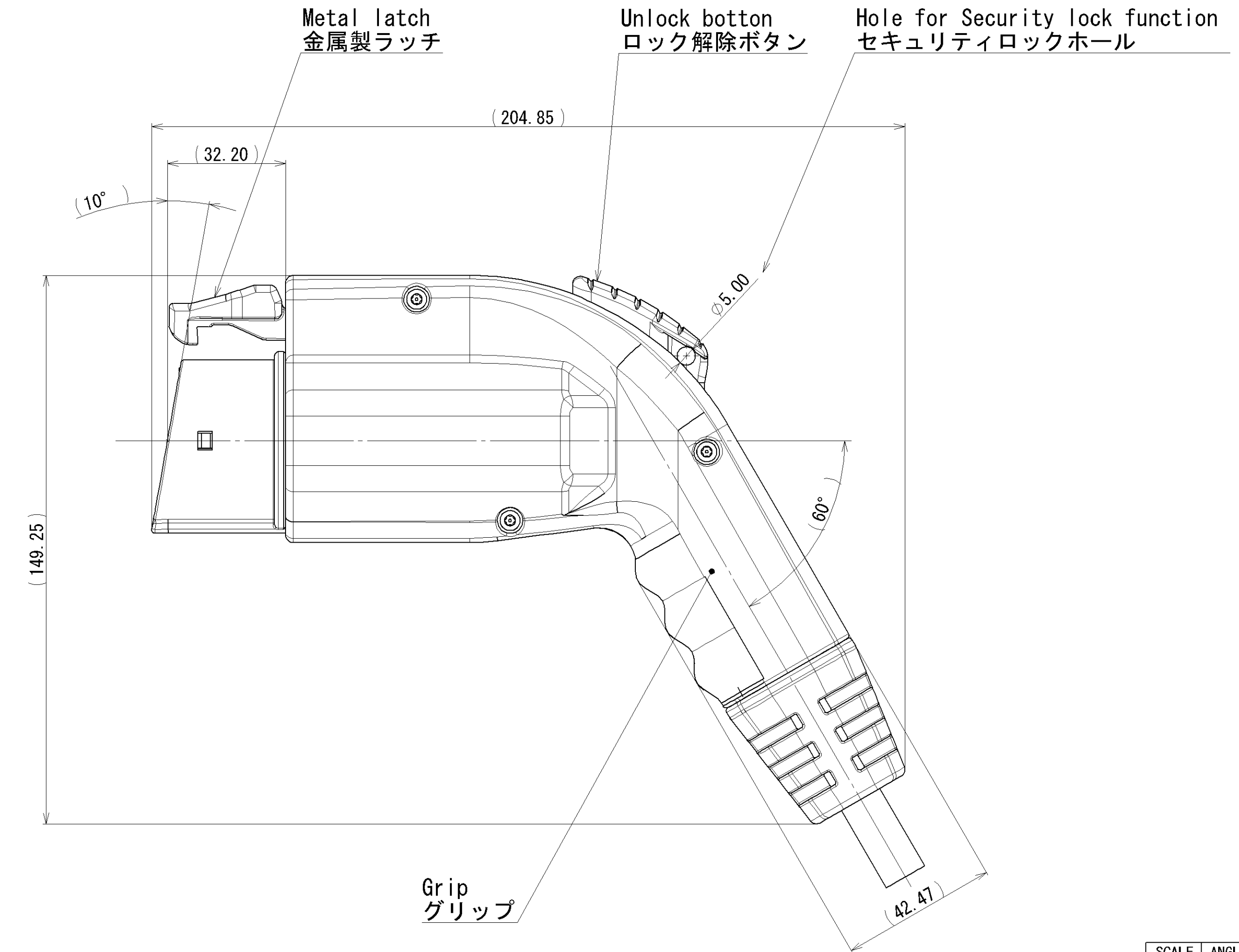
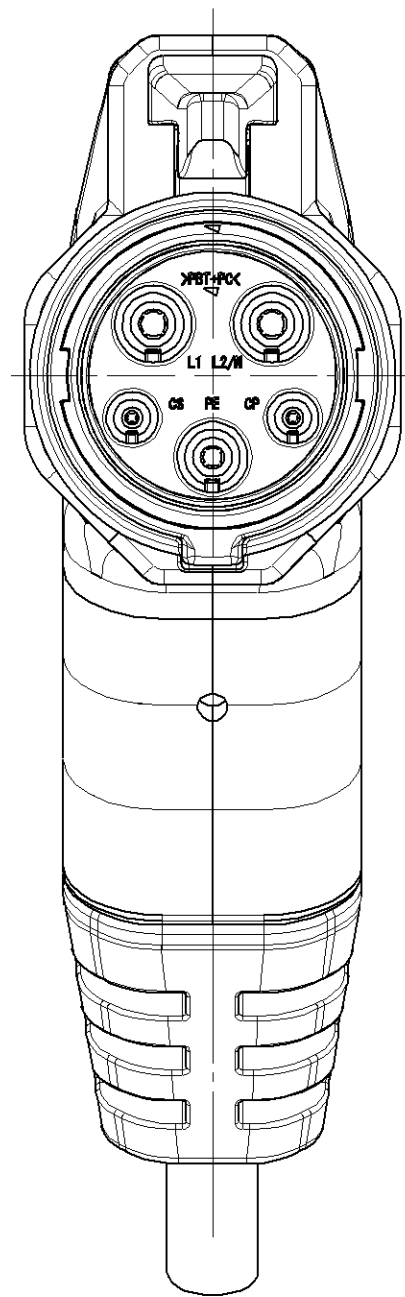
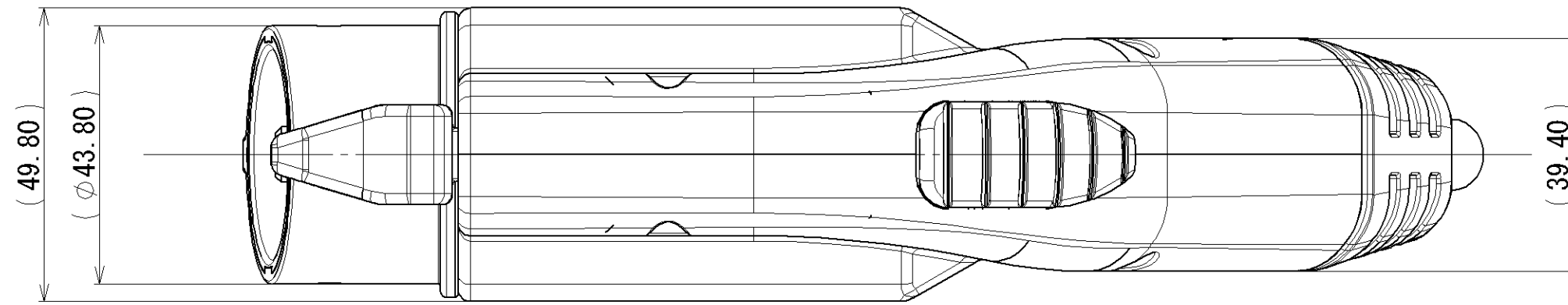

SCALE	ANGLE
1:1	3

NAME	AC CHARGING CONNECTOR / VEHICLE-SIDE CONNECTOR
	AC充電コネクタ / 車両側コネクタ
	YAZAKI CORPORATION